

# Parrilla GMB 100

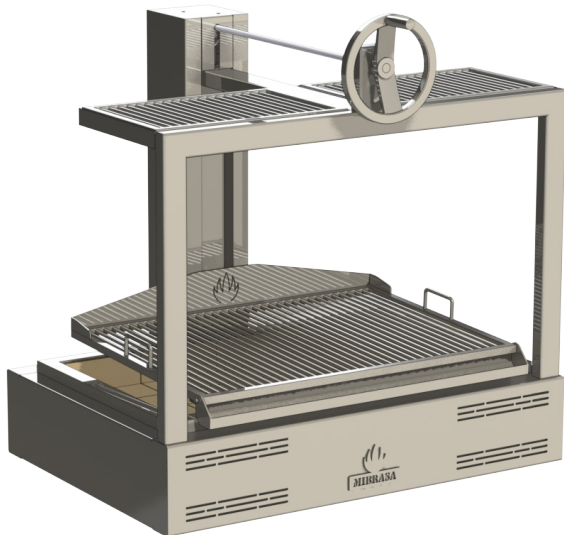

## FEATURES

Precision and strength defines the new PARRILLA by MIBRASA®.

Thanks to the carefully engineered design with elevation system and positional brake, the Mibrasa® Parrilla effortlessly regulates the height of the grill from the heat of embers with maximum safety and minimum maintenance.

The Mibrasa® Parrilla lets us sear, cook and rest our ingredients, achieving the optimal result every time.

### ERGONOMIC DESIGN. MAXIMUM QUALITY AND SECURITY

With a sloping grill, the grease runs down the weld-free grill bars to prevent grease build-up. Grease drips down to the collector with an easy to remove mechanism ready to clean.

The base is lined with refractory bricks to ensure maximum heat efficiency and resistance to pure fire. And the built-in cooling system in outer case guarantees a maximum level of security.

Built using quality steels providing strength and durability; ergonomically designed for practicality and ease of use, each feature plays a crucial part in delivering the ultimate grilling machine for every chef.

## TECHNICAL INFORMATION

Fire up time <sup>1</sup>	30 min-average
Cooking temperature	250 °C
Initial charcoal load <sup>1</sup>	15 kg
Charcoal load duration <sup>2</sup>	7 h
Equivalent power*	4.5 kW
Exhaust rate	2800 m <sup>3</sup> /h
Installation height*	700 mm
Net weight <sup>3</sup>	265 kg

\*Approximate data

1. Consult instruction manual

2. Will vary depending on quality of charcoal

3. Weight with accessories included

### GRILL DIMENSIONS

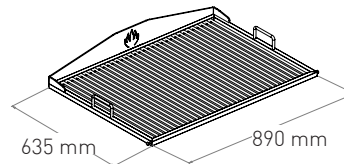

### HEATING RACK DIMENSIONS

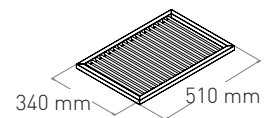

## INCLUDED ACCESSORIES

- Round bar grill
- 2 heating rack grills
- Ash shovel
- Ember poker
- Mibrasa tongs
- Grill brush
- Mibrasa Ecofire fire-lighters

## OPTIONAL ACCESSORIES

- V-shape grill
- Extra round bar grill
- Parrilla stand

Specifications and design are subject to change without notice.

## QUALITY GUARANTEE





# Parrilla GMB 100

FRONT VIEW

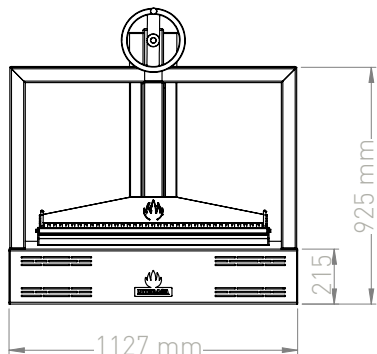

SIDE VIEW

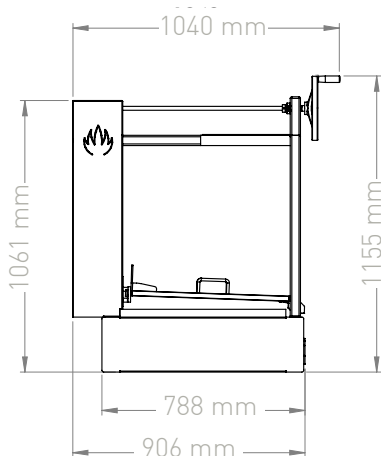

TOP VIEW

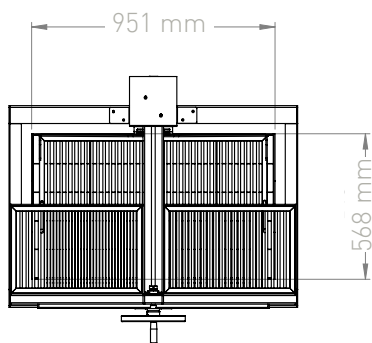

## GRILL TYPES

Round bar grill

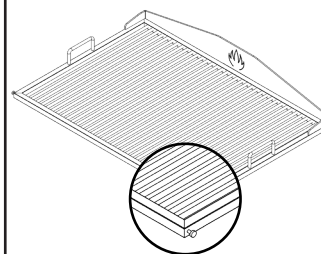

V-shape grill

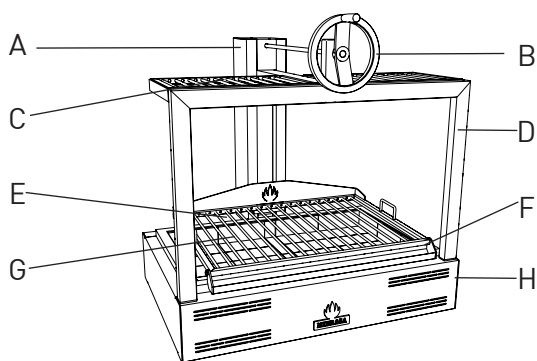
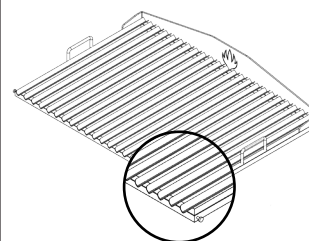

A	Reverse elevating system
B	Elevating wheel
C	Heating rack
D	Structure
E	Grill
F	Grease collector
G	Refractory bricks
H	Main body

## SHIPMENT

- Gross weight: 375 kg
- Package size (WxDxH): 1100 x 1300 x 1200 mm

Revit drawings available on request at [mibrasa@mibrasa.com](mailto:mibrasa@mibrasa.com)

### Safety standards and installation guidelines

- Do not place combustible materials within a distance of 710 mm from the top, bottom, rear or side of the Mibrasa® Parrilla GMB.
- Combustible floor protection dimensions: a. 762 mm to each side of the Parrilla  
b. 914 mm in front of the Parrilla
- Clearances to construction/other appliances: a. Unit to backwall = 76 mm  
b. Unit to sidewalls = 76 mm
- The workspace for the chef should be 700 mm from the front of the Parrilla.
- A lifting device should be used whenever possible to lift the Parrilla and place on the countertop/stand.

For further information, please consult the instruction manual.

Specifications and design are subject to change without notice.